

Category: Telecom

AM-221423

This enclosure provides additional capacity to an existing cabinet when that capacity has reached its maximum. It is retro-fitted in the field using an optional mounting template with step by step instructions and common hardware fasteners.

Common Uses:

These versatile enclosures mount to an existing site cabinet to add an extra 6 RU of rack space. This is a cost effective alternative to adding capacity with out the cost of an additional cabinet or where the site space is limited.

Specifications:

- **Size:** 22" Tall x 14" Wide x 23" Deep
- **Weight:** 60 lbs approx.
- **Ship Weight:** 85 lbs approx.
- **Material:** 16 Gauge Galvanized Steel
- **Powder Coated:** 1000 hour salt spray test in compliance with GR487 standards.
- **Rating:** Designed and built to NEMA 3R Standards

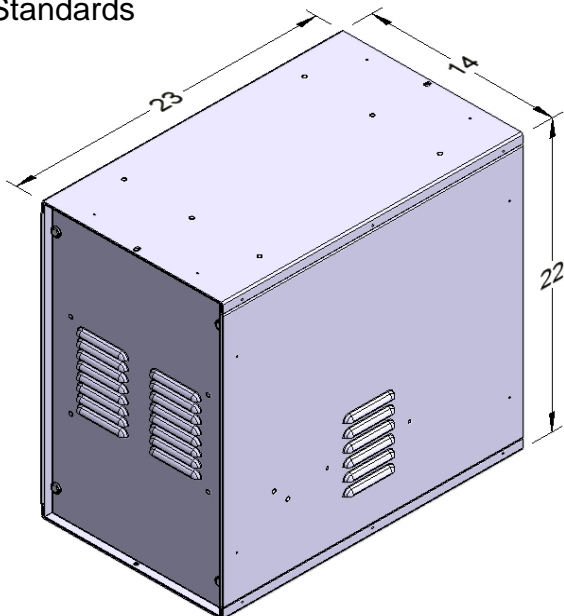

Features:

- Offers 6 RU of rack space
- Filtered ventilation louvers on front and rear doors
- Thermostatically controlled AC or DC exhaust fan (optional)
- Air Conditioner options available
- Can be mounted to either side of the existing cabinet.
- Front and rear doors are sealed with gasketing and secured with security bolts with cup washers. (can wrench/216 tool accessible per Telcordia standards)
- 16 GA galvanized steel with powder coated finish, bolted and riveted construction
- Side cable entry knock-outs
- Reversible equipment mounting rack options
- Climate control options are also available