

Category: Digital Signage

This Flat Panel Enclosure (**FPE**) is used when there is a need to control the application, configuration or the environment of commercial grade displays

FPE: Is a modular enclosure platform for displays

This versatile solution can be modified to fit any commercial display application and allows the user the freedom to configure the display with a variety of input and computing components.

Specifications:

- **Size:** 24" to 52" display sizes
(42" display size, rear view shown below)
- **Weight:** 20 lbs approx. (as shown)
- **Ship Weight:** 28 lbs approx. (as shown)
- **Material:** Aluminum
- **Finish:** Powder Coat Matte Black
- **Loading:** Can support approx. 125 lbs

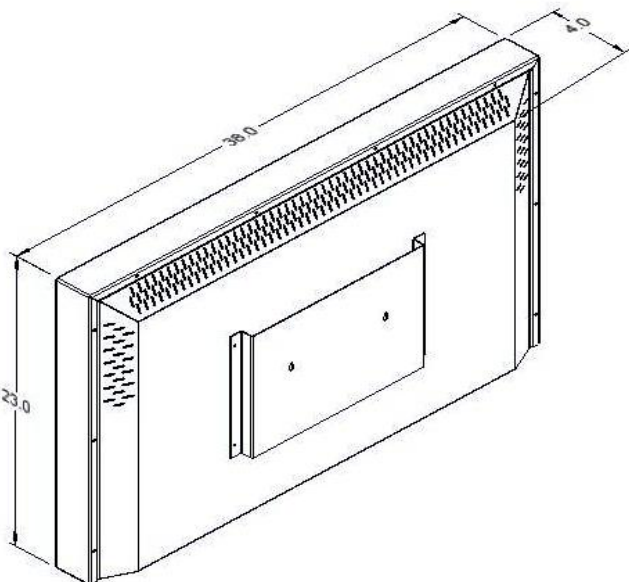

Features:

- Made from rugged light weight aluminum
- Simple wall mount design allows for a one man installation
- Clam shell design allows for easy access to back of display for installation and maintainability
- Platform is customizable to meet the needs of special input devices, single board computers and controls
- Stainless Steel option also available
- Integrated mounting bracket that conforms to VESA standards making it easy to mount to the back of any display.
- Perforated top and sides to dissipate heat
- Fan options available
- Branding options are available
- Optional CD/DVD drive integration.